

Ruote per profilati in alluminio

Doppie rotelle orientabili, avvitate

Doppie rotelle orientabili



RoHS10

Tipo	Ruota		Rotella		Cuscinetto	
	Materiale	Trattamento superficie	Materiale (Colore)	Snodo	Rotella	
HCHA, HCHAS	Nylon	-	Nylon	-	-	-

HCHA (8-40, 8-60, 8-100, 12-60, 12-100, 12-150, 16-150, 16-170)
HCHAS (8-20, 8-30, 12-20, 12-30)

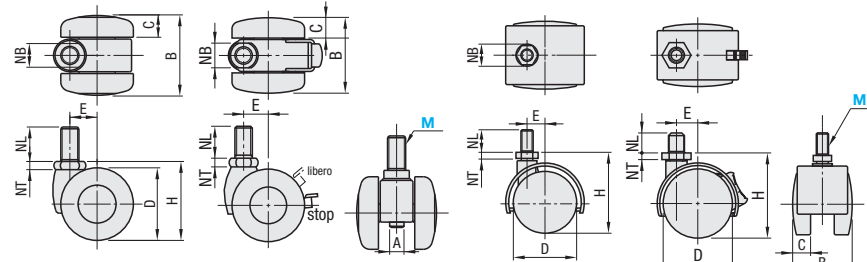

Tipo	M (Fil. grossa)	Carico ammesso		HCHA											HCHAS			
		(kgf)	(N)	Prezzo unitario											Prezzo unitario			
				1 - 9 pz.											10-50			
HCHA HCHAS (Con freno)	8	20*	196	40	50	-	41	13	15	13	4	15						
		30*	294	50	60		45	14	18									
		40	396	40	43.5	7	44	12	15	14	4.5	12						
		60	594	50	57.5		41	13	15									
		100	990	60	68.5	8	49	14	17	17	6	14						
		20*	196	40	50		41	13	15									
	12	30*	294	50	60		45	14	18	19	4	15						
		60	594	50	57.5		41	13	15									
		100	990	60	68.5	8	49	14	17	17	6	14						
		150	1485	60	69	10	59	17.5	17			22						
		150	1485	75	84.5		64	18.5	20			25						
		170	1683	75	84.5		64	18.5	20			25						

Ordering Example: HCHA12 - 100

Montaggio
 Ruotare la testa della vite esagonale nella parte inferiore della rotella (indicata in figura dalla dimensione A), in modo che ruoti la parte filettata superiore della vite. Serrare attraverso le sedi mostrate in figura come NB. Per i tipi con *, montare e serrare la parte NB con una chiave.

Orientabili avvitate



RoHS10

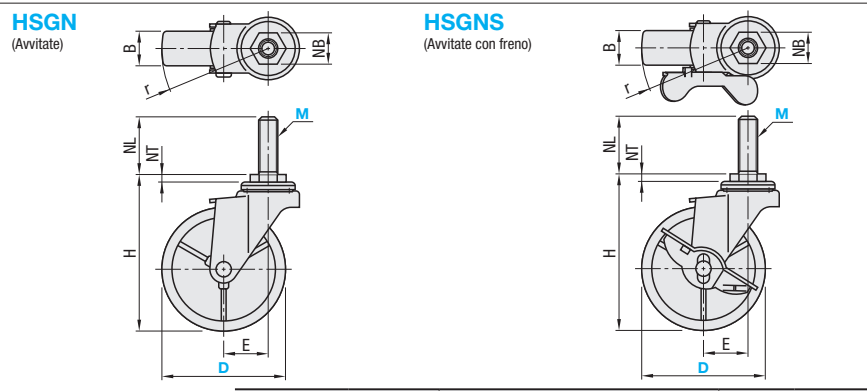

Tipo	Ruota		Rotella		Cuscinetto	
	Materiale	Trattamento superficie	Materiale (Colore)	Snodo	Rotella	
HSGN	EN 1.0320 equiv. (laminato a caldo)	Cromatura trivalente	Gomma sintetica (Nero), Uretano (Marrone), Nylon (Bianco)	Fornita	Non fornita	

Tipo corpo	Codice componente	Tipo	M (Fil. grossa)	Materiale rotella	Carico ammesso (N)											Massa (g)			Prezzo unitario					
					Larghezza rotella B											R			U			N		
					H	R	U	N	E	NB	NT	NL	r	R	U	N	R	U	N	R	U	N		
Orientabili avvitate	HSGN	50	8	R (Gomma) U (Uretano) N (Nylon)	68	20	21	21	22	14	4.8	14	47	300	380	400	195	175	165	165				
		12	85		21	21	21	23	19	35	56	400	400	270	220	210								
		65	12		95	21	21	27	4	40	82	400	450	500	310	240	225							
		75	12		126	25	28	25	31	21	4	40	82	500	600	600	585	435	405					
Orientabili avvitate con freno	HSGNS	50	8	R (Gomma) U (Uretano) N (Nylon)	68	20	21	21	22	14	4.8	14	49	300	380	400	220	200	190					
		12	85		21	21	21	23	19	35	57	300	400	305	255	235								
		65	12		95	21	21	27	4	40	65	400	450	500	340	275	250							
		75	12		126	25	28	25	31	21	4	40	82	500	600	600	650	620	585					

Ordering Example: HSGN75 - 12 - U

Ruote per profilati in alluminio/Staffe per ruote per attacco laterale/Piastre di montaggio per ruote e piedi di livellamento

Rotella in gomma

Rotella in gomma



RoHS10

Tipo	Ruota		Rotella		Cuscinetto	
	Materiale	Trattamento superficie	Materiale (Colore)	Snodo	Rotella	
HSMA	EN 1.0320 equiv. (laminato a caldo)	Cromatura trivalente	Gomma sintetica (Nero)	Fornita	Fornita	

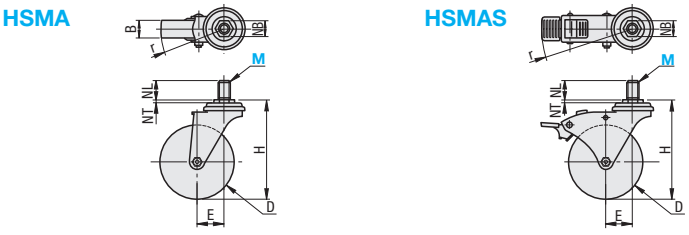

Tipo corpo	Codice componente	Tipo	Carico ammesso		D	H	B	E	NB	NT	NL	r	Masa (g)	Prezzo unitario
			M (Fil. grossa)	W (kgf) (N)										
Orientabile	HSMA	12	60	594	75	105	25	30	23	4	25	72	500	
		16	70	695	100	137	25	35	35			89	700	
Orientabili con freno	HSMAS	12	60	594	75	105	25	30	23	4	25	105	640	
		16	70	695	100	137	25	35	35			128	950	

Ordering Example: HSMAS16 - 70

Staffe per ruote per attacco laterale



RoHS10

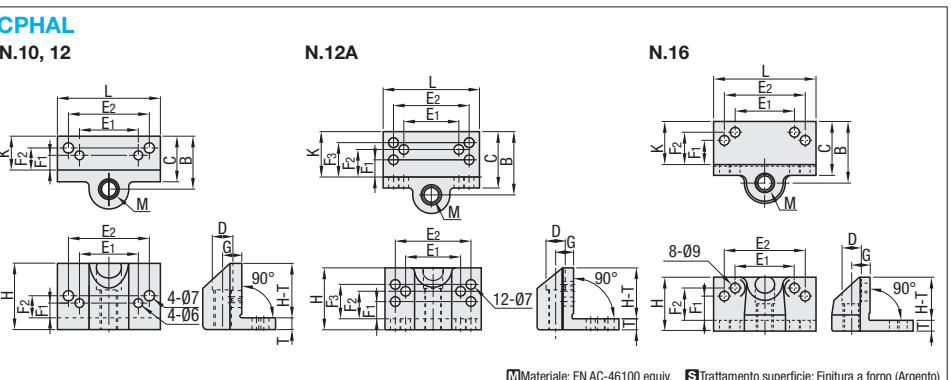

Codice componente	Tipo	N.	Profilato (Cava singola)	M (Fil. grossa)	H	L	B	K	C	T	D	G	Dim. foro di montaggio					Masa (g)	Prezzo unitario
													E1	E2	F1	F2	F3		
CPHAL	10	10	20mm, 30mm	10	45	70	36	23	31	8	14	13	40	55	10	15	-	135	
	12	12	25mm, 40mm, 50mm	12	45	70	46	33	41	8	14	13	40	55	10	15	-	165	
	12A	12	25mm, 40mm, 50mm	12	45	70	46	33	41	8	14	13	40	55	10	15	-	165	
	16	16	45mm, 60mm	16	50	95	57	40	50	10	20	17	55	75	22.5	30	-	285	

Ordering Example: CPHAL10



Piastre di montaggio per ruote e piedi di livellamento



RoHS10

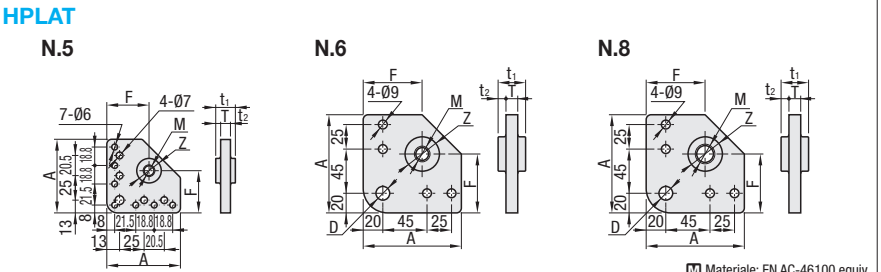

Codice componente	Tipo	N.	Profilato	A	T	M	Z	D	F	t1	t2	Masa (g)	Prezzo unitario	Sconto volumi elevati
	6	40mm	100	12	16	35	14	60	28	8	281			
	8	40mm	100	12	20	35	14	60	28	8	273			

Ordering Example: HPLAT6