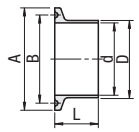
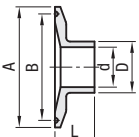
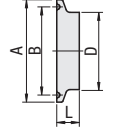
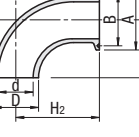
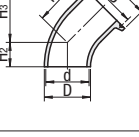
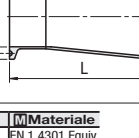
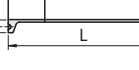

Raccordi per tubi sanitari

Viola x Saldatura

Raccordi per tubi sanitari

Doppia viola

 <p>RoHS 10</p>	Viola Tipo: SNFR, SNFRS Materiale: EN 1.4301 Equiv., EN 1.4404 Equiv.	
	Viola riduttrice Tipo: SNFRE Materiale: EN 1.4301 Equiv.	
Terminale viola Tipo: SNFK Materiale: EN 1.4301 Equiv.		
Viola x Gomito a saldare Tipo: SNFE, SNFES Materiale: EN 1.4301 Equiv., EN 1.4404 Equiv.		
Viola x Gomito a saldare 45° Tipo: SNFHE, SNFHES Materiale: EN 1.4301 Equiv., EN 1.4404 Equiv.		
Viola x Riduttore saldato Tipo: SNFRD, SNFRDS Materiale: EN 1.4301 Equiv., EN 1.4404 Equiv.		
Viola x Riduttore sfalsatosaldato Tipo: SNFRY, SNFRYS Materiale: EN 1.4301 Equiv., EN 1.4404 Equiv.		

Cod. comp.	Tipo	N.	D	d	A	B	L	SNFR		SNFRS	
								Prezzo unitario	Sconto volumi elevati	Prezzo unitario	Sconto volumi elevati
SNFRS	8A	13.8	10.5	34.0	27.5	17.0	-	-	-	-	
	10A	17.3	14.0				-	-	-	-	
	15A	21.7	17.5				-	-	-	-	
SNFRE	1S	25.4	23.0	50.5	43.5	21.0	-	-	-	-	
	1.5S	38.1	35.7	50.5	43.5		-	-	-	-	
	2S	50.8	47.8	64.0	56.5		-	-	-	-	
	2.5S	63.5	59.5	77.5	70.5		-	-	-	-	
	3S	76.3	72.3	91.0	83.5		-	-	-	-	

Per ordini superiori ai valori indicati, controllare con WOS.

Cod. comp.	Tipo	N.	Nominale	D	d	A	B	L	Prezzo unitario		Sconto volumi elevati	
									Q.tà 1 - 9	10-20	Q.tà 1 - 9	10-20
SNFRE	1S	8A	13.8	10.5	50.5	43.5	21.0	-	-	-	-	
		10A	17.3	11.3				-	-	-	-	
		15A	21.7	15.7				-	-	-	-	
	1.5S	10A	17.3	11.3	50.5	43.5	21.0	-	-	-	-	
		15A	21.7	15.7				-	-	-	-	
		20A	27.2	21.2				-	-	-	-	
2S	15A	21.7	15.7	64.0	56.5	21.0	-	-	-	-		
	20A	27.2	21.2				-	-	-	-		
	25A	34.0	28.4				-	-	-	-		
2.5S	20A	27.2	21.2	77.5	70.5	21.0	-	-	-	-		
	25A	34.0	28.4				-	-	-	-		
	32A	42.7	37.1				-	-	-	-		
	25A	34.0	28.4				-	-	-	-		
3S	32A	42.7	37.1	91.0	83.5	21.0	-	-	-	-		
	40A	48.6	43.0				-	-	-	-		

Per ordini superiori ai valori indicati, controllare con WOS.

Cod. comp.	Tipo	N.	D	A	B	L	Prezzo unitario		Sconto volumi elevati	
							Q.tà 1 - 9	10-14	Q.tà 1 - 9	10-14
SNFK	1S	38.1	50.5	43.5	11.0	-	-	-	-	
	1.5S	50.8	64.0	56.5		-	-	-	-	
	2S	63.5	77.5	70.5		-	-	-	-	
	2.5S	76.3	91.0	83.5		-	-	-	-	
	3S	76.3	91.0	83.5		-	-	-	-	

Il profilo di SNFK1S e 1.5S è lo stesso. Per ordini superiori ai valori indicati, controllare con WOS.

Cod. comp.	Tipo	N.	D	d	A	B	H1	H2	SNFE		SNFES	
									Prezzo unitario	Sconto volumi elevati	Prezzo unitario	Sconto volumi elevati
SNFE SNFES	1S	25.4	23	50.5	43.5	34	55	-	-	-	-	
	1.5S	38.1	35.7	50.5	43.5	49	70	-	-	-	-	
	2S	50.8	47.8	64.0	56.5	61	82	-	-	-	-	
	2.5S	63.5	59.5	77.5	70.5	84	105	-	-	-	-	
	3S	76.3	72.3	91.0	83.5	89	110	-	-	-	-	

Per ordini superiori ai valori indicati, controllare con WOS.

Cod. comp.	Tipo	N.	D	d	A	B	H1	H2	H3	SNFHE		SNFHES	
										Prezzo unitario	Sconto volumi elevati	Prezzo unitario	Sconto volumi elevati
SNFHE SNFHES	1S	25.4	23	50.5	43.5	36.8	15.8	43.9	-	-	-	-	
	1.5S	38.1	35.7	50.5	43.5	44.7	23.7	49.5	-	-	-	-	
	2S	50.8	47.8	64.0	56.5	52.6	31.6	59.8	-	-	-	-	
	2.5S	63.5	59.5	77.5	70.5	63.0	42.0	71.9	-	-	-	-	
	3S	76.3	72.3	91.0	83.5	73.6	52.6	84.2	-	-	-	-	

Per ordini superiori ai valori indicati, controllare con WOS.

Cod. comp.	Tipo	N.	D	d	d1	A	B	L	SNFRD		SNFRDS	
									Prezzo unitario	Sconto volumi elevati	Prezzo unitario	Sconto volumi elevati
SNFRD SNFRDS	1.5S	38.1	35.7	23	50.5	43.5	88	-	-	-	-	
	2S	50.8	47.8	35.7	50.5	43.5		-	-	-	-	
	2.5S	63.5	59.5	47.8	64.0	56.5		-	-	-	-	
	3S	76.3	72.3	59.5	77.5	70.5		-	-	-	-	

La viola è più piccola di una misura. Es.) Per N.2S, 2S (tubo) x1.5S (parte viola)

Per ordini superiori ai valori indicati, controllare con WOS.

Cod. comp.	Tipo	N.	D	d	d1	A	B	L	SNFRY		SNFRYS	
									Prezzo unitario	Sconto volumi elevati	Prezzo unitario	Sconto volumi elevati
SNFRY SNFRYS	1.5S	38.1	35.7	23	50.5	43.5	88	-	-	-	-	
	2S	50.8	47.8	35.7	50.5	43.5		-	-	-	-	
	2.5S	63.5	59.5	47.8	64.0	56.5		-	-	-	-	
	3S	76.3	72.3	59.5	77.5	70.5		-	-	-	-	

La viola è più piccola di una misura. Es.) Per N.2S, 2S (tubo) x1.5S (parte viola)

Per ordini superiori ai valori indicati, controllare con WOS.

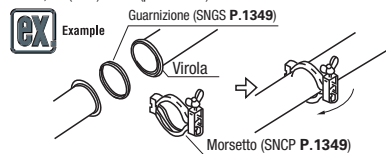

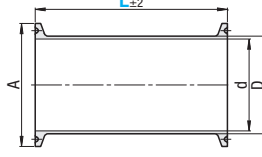
 <p>RoHS 10</p>	Doppia viola dritti Tipo: SNPAA Materiale: EN 1.4301 Equiv.	
--	--	---

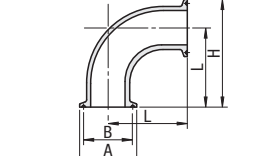
 <p>RoHS 10</p>	Doppia viola, gomito Tipo: SNBE, SNBES Materiale: EN 1.4301 Equiv., EN 1.4404 Equiv.	
--	---	---

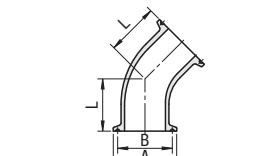
 <p>RoHS 10</p>	Doppia viola, gomito 45° Tipo: SNBHE, SNBHES Materiale: EN 1.4301 Equiv., EN 1.4404 Equiv.	
--	---	---

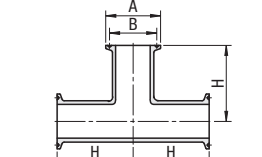
 <p>RoHS 10</p>	Doppia viola, Attacchi a T Tipo: SNBT, SNBTS Materiale: EN 1.4301 Equiv., EN 1.4404 Equiv.	
--	---	---

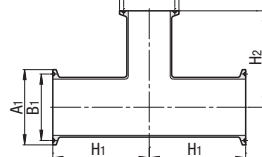
 <p>RoHS 10</p>	Doppia viola, Riduttori a T Tipo: SNBTD	
--	---	---

Cod. comp.	Tipo	N.	Selezione L	D	d	A	Prezzo unitario 1 - 4 pz.			Sconto volumi elevati 5 - 10 pz.		
							L100	L200	L300	L100	L200	L300
SNPAA	1S	100	150	200	25.4	23	50.5	-	-	-	-	-
	1.5S	150	200	250	38.1	35.7	50.5	-	-	-	-	-
	2S	200	250	300	50.8	47.8	64	-	-	-	-	-

Per ordini superiori ai valori indicati, controllare con WOS.

Cod. comp.	Tipo	N.	A	B	L	H	SNBE		SNBES	
							Prezzo unitario	Sconto volumi elevati	Prezzo unitario	Sconto volumi elevati
SNBES	8A	34.0	27.5	55	72	-	-	-	-	
	10A	34.0	27.5	55	72	-	-	-	-	
	15A	34.0	27.5	55	72	-	-	-	-	
SNBE SNBES	1S	50.5	43.5	55	80.3	-	-	-	-	
	1.5S	50.5	43.5	70	95.3	-	-	-	-	
	2S	64.0	56.5	82	114	-	-	-	-	
	2.5S	77.5	70.5	105	143.8	-	-	-	-	
	3S	91.0	83.5	110	155.5	-	-	-	-	

Per ordini superiori ai valori indicati, controllare con WOS.

Cod. comp.	Tipo	N.	A	B	L	SNBHE		SNBHES	
						Prezzo unitario	Sconto volumi elevati	Prezzo unitario	Sconto volumi elevati
SNBHE SNBHES	1S	50.5	43.5	36.8	-	-	-	-	
	1.5S	50.5	43.5	44.7	-	-	-	-	
	2S	64.0	56.5	52.6	-	-	-	-	
	2.5S	77.5	70.5	63.0	-	-	-	-	
	3S	91.0	83.5	73.6	-	-	-	-	

Per ordini superiori ai valori indicati, controllare con WOS.

Cod. comp.	Tipo	N.	A	B	H	SNBT		SNBTS	
						Prezzo unitario	Sconto volumi elevati	Prezzo unitario	Sconto volumi elevati
SNBTS	8A	34.0	27.5	55	-	-	-	-	
	10A	34.0	27.5	55	-	-	-	-	
	15A	34.0	27.5	55	-	-	-	-	
SNBT SNBTS	1S	50.5	43.5	55	-	-	-	-	
	1.5S	50.5	43.5	70	-	-	-	-	
	2S	64.0	56.5	82	-	-	-	-	
	2.5S	77.5	70.5	105	-	-	-	-	
3S	91.0	83.5	110	-	-	-	-		

Per ordini superiori ai valori indicati, controllare con WOS.

Cod. comp.	Tipo	N.	A1	B1	H1	A2	B2	H2	Prezzo unitario
									Q.tà 1 - 5
SNBTD	1.5S-1S	50.5	43.5	70.0	50.5	43.5	66.0	-	
	2S-1S	64.0	56.5	82.0	50.5	43.5	72.0	-	
	2S-1.5S	64.0	56.5	82.0	50.5	43.5	85.0	-	
	2.5S-1.5S	77.5	70.5	105.0	50.5	43.5	91.0	-	
2.5S-2S	77.5	70.5	105.0	64.0	56.5	103.0	-		

Per ordini superiori ai valori indicati, controllare con WOS.

Ordering Example
 Cod. comp. - Nominale
 SNFR2S - SNFRE3S - 32A

Ordering Example
 Cod. comp. - L
 SNPAA1S - SNBES8A - SNBTD2S-1S - 150

