



JECTOR PUNCHES FOR HEAVY LOAD

— FINISHED FOR RETAINERS · WPC® TREATMENT · HW COATING · SPRING AND PIN REINFORCED TYPE —

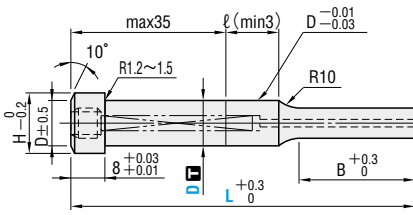

Projection length of the jector pin is 2mm for reinforced types and 4mm for non-reinforced types.

For details of jector holes, refer to Jector Punch Blanks. P.238
For details of jector pins, refer to Jector Pin Sets. P.241

Type	Shank diameter D tolerance	M H	Catalog No.			The tip shape can be selected from Tip shape A~G in the figure below.
			Type	Tip shape	B Tip length	
—WPC® treatment— 	Dm5		W-APJ Spring and pin reinforced type	A D R E G	S L	 <p>The tip edge are very slightly rounded.</p>
			W-APJV Spring and pin reinforced type			
—HW coating— 	D+0.005/0	HW-APJ Spring and pin reinforced type				
HW-APJV Spring and pin reinforced type						
AW-APJ Spring and pin reinforced type						
AW-APJV Spring and pin reinforced type						
AHW-APJ Spring and pin reinforced type		AHW-APJV Spring and pin reinforced type				

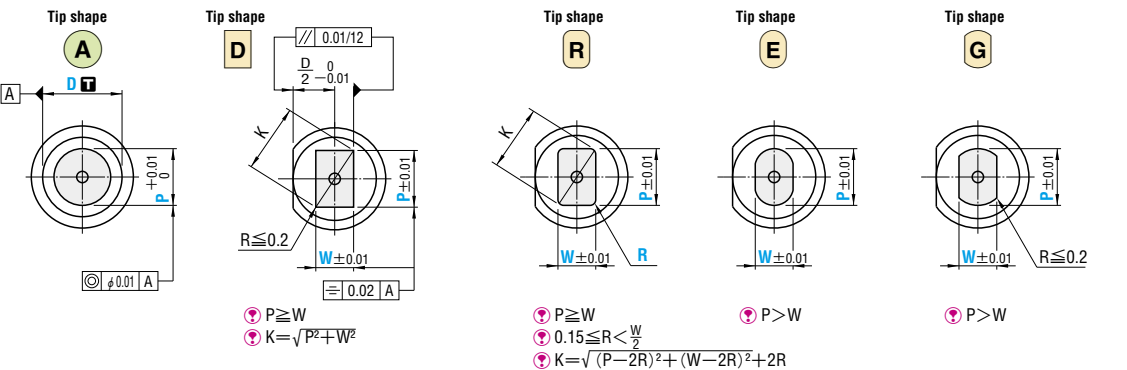

Catalog No.	Type	Tip shape	B Tip length	D	L	0.01mm increments				B	H			
						(A) min.	P max.	D R E G P·Kmax.	P·Wmin.			R		
—WPC® treatment— W-APJ (Dm5) W-APJV (D+0.005) Spring and pin reinforced type —HW coating— HW-APJ HW-APJV Spring and pin reinforced type	A D R E G	S L	8 10 13 16 20 25	8 10 13 16 20 25	(50) 60 70 80 90 100 (110) (120) (130)	4.00 ~ 7.99	7.97	4.00		0.15 ≤ R < W/2 (R only)	13	15		
						5.00 ~ 9.99	9.97	5.00						
						6.00 ~ 12.99	12.97	6.00						
						10.00 ~ 15.99	15.97	6.00						
						13.00 ~ 19.99	19.97	6.00						
						18.00 ~ 24.99	24.97	6.00						
						4.00 ~ 7.99	7.97	4.00					13	15
						5.00 ~ 9.99	9.97	5.00						
						6.00 ~ 12.99	12.97	6.00						
						10.00 ~ 15.99	15.97	6.00						
13.00 ~ 19.99	19.97	6.00												
18.00 ~ 24.99	24.97	6.00												

The spring constants of W-APJV, AW-APJV, HW-APJV, and AHW-APJV are twice those of W-APJ, AW-APJ, HW-APJ, and AHW-APJ respectively. L (110) (120) (130) → L110, 120, and 130 cannot be used for spring and pin reinforced types.
L (50) → B=8 If the full length is (50), the tip length is 8mm in all cases.
A: P > D - 0.03 → ℓ = 0 If P > D - 0.03 for a round punch, D - 0.01 / -0.03 (press-in lead) is not included.
D R E G: P · K > D - 0.05 → ℓ = 0 If P · K > D - 0.05 for a shaped punch, D - 0.01 / -0.03 (press-in lead) is not included.

Order Catalog No. — L — P — W — R (R only)
W-APJAS 20 — 80 — P15.00

Effect of spring and pin reinforced type
The spring constant is twice that of the standard type, resulting in improved scrap removal. In addition, the improved strength under the pin head prevents breakage below the head.

Days to Ship **Quotation**

Alterations Catalog No. — L(LC) — P — W — R — (BC·KC, etc.)
W-APJAS 20 — LC79 — P15.00 — W6.00 — R — BC13

Alteration	Code	A	D R E G	1Code
Alterations to tip	BC	Tip length change (shorter than standard) 2 ≤ BC < B 0.1 mm increments		
	PRC	Rounding of tip side edge 0.3 ≤ PRC ≤ 1 0.1 mm increments P RC ≤ (P - d - 0.5) / 2 d, dimension P.238 Cannot be combined with PCC.		
	PCC	Chamfering to tip side edge 0.3 ≤ PCC ≤ 1 0.1 mm increments P CC ≤ (P - d - 0.5) / 2 d, dimension P.238 Cannot be combined with PRC.		
	PKC	Tip tolerance change P +0.01 / 0 → +0.005 / 0 P dimension can be selected in 0.01 mm increments. HW coating cannot be used for D > 13.	Tip tolerance change P · W ± 0.01 → +0.01 / 0	Quotation
	Alterations to full length	LC	Full length change LC < L (reduction in tip length) 0.1 mm increments (If combined with LKC, 0.01 mm increments can be selected.) Tip length B is shortened by (L - LC). The projection length of the jector pin is 2mm for spring and pin reinforced types and 4mm for non-reinforced types.	
LKC		Full length tolerance change L +0.3 / 0 → +0.05 / 0		

Alteration	Code	A	D R E G	1Code
Alterations to head	KC	Addition of single key flat to head	Key flat position change 1° increments	
	WKC	Addition of double key flats in parallel	Double key flats in parallel Can be combined with KC.	
	KFC	Double key flats at 0° and a selected angle 1° increments	Double key flats at 0° and a selected angle 1° increments	
	NKC	No key flat		Quotation
Alterations to shank	SKC	Single key flat on shank A P ≤ D - 2.2 W ≤ D - 2.2 (Machining width 1) Cannot be combined with KC·WKC·KFC.		
	AC	The jector pin is removed to create an air path and the side vent hole is plugged from the inside by inserting a resin (ABS) ring.		
	NC	The jector pin is removed. Cannot be combined with AC.		
NDC	No press-in lead ℓ ≥ 3 → ℓ = 0			

Price **Quotation**